

REVISIONS				
ZONE	REV	DESCRIPTION	DATE	APPROVED
	A	INITIAL RELEASE	10/10/2012	

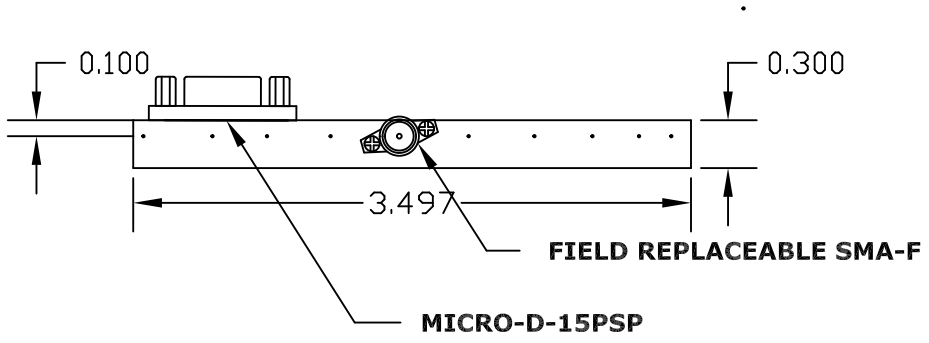
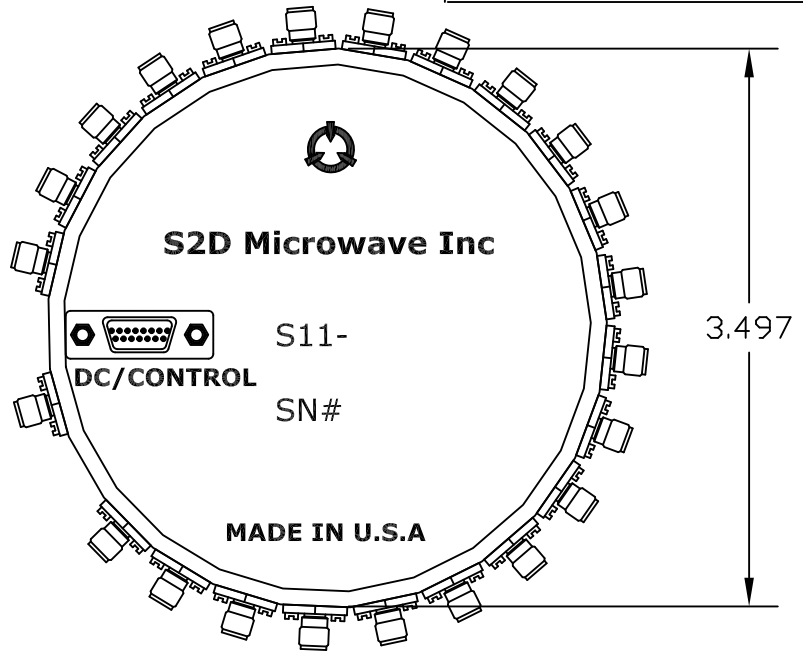

All Dimensions in Inches Tolerances: Fractions Decimals Angles - ±0.01 ±3° ±0.005	
Model# S11 -	
Material: AL Alloy 6061-T6 per QQ-A-250/11	
Plating: Electroless nickel per MIL-C-26074	

S2D Microwave Inc.
www.s2dmicrowave.com

**S11 - PACKAGE
OUTLINE DRAWING**

SIZE	FSCM NO.65BW0	DWG NO. 100-1012-S11-01	REV
SCALE: None		SHEET 1 of 1	

NOTE: Specifications are subject to revision or change
Units are designed to meet the environmental rating.
For environmental testing please contact sales@s2dmicrowave.com.